

TAEGUTEC
SPEEDTEC
HIGH SPEED & FEED LINES

MINIRUSH

INTERNAL GROOVING

Mini inserto per
lavorazioni interne
poco profonde

✓ Inserto piccolo
per industria
minuteria

✓ Sistema di
bloccaggio
sicuro

✓ Inserto rettificato di
precisione per finitura

✓ Ottima evacuazione
truciolo

✓ Refrigerazione interna



TaeguTec
Member IMC Group

TMIS 8

Inserto di precisione per scanalature interne poco profonde

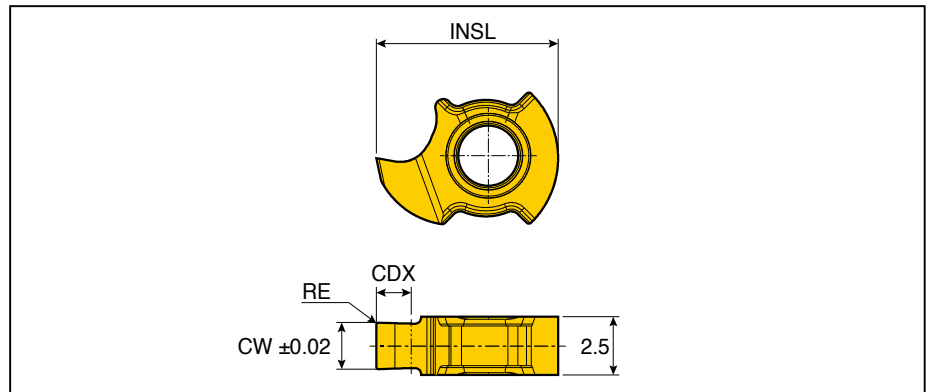

Descrizione	Avanz. (mm/giro)	Dimensioni (mm)				Grado
		CW	RE	CDX	INSL	TT4430
TMIS 8-0.50-0.00	0.01-0.03	0.50	0.00	0.70	7.8	●
8-1.00-0.00	0.01-0.03	1.00	0.00	1.50	7.8	●
8-1.50-0.05	0.01-0.03	1.50	0.05	1.50	7.8	●
8-2.00-0.10	0.01-0.03	2.00	0.10	1.50	7.8	●

●: Standard