

# QUADIRUSH

INTERNAL GROOVING

**Inserto di piccole dimensioni  
con 4 taglienti per  
scanalatura interna**

✓ **Inserto economico**

✓ **Bloccaggio rigido**

✓ **Grande varietà di misure di inserto**

✓ **Ottima evacuazione truciolo**

✓ **Facile da usare**

# TQHIR/L



## Utensili per scanalatura interna con fori di lubrificazione

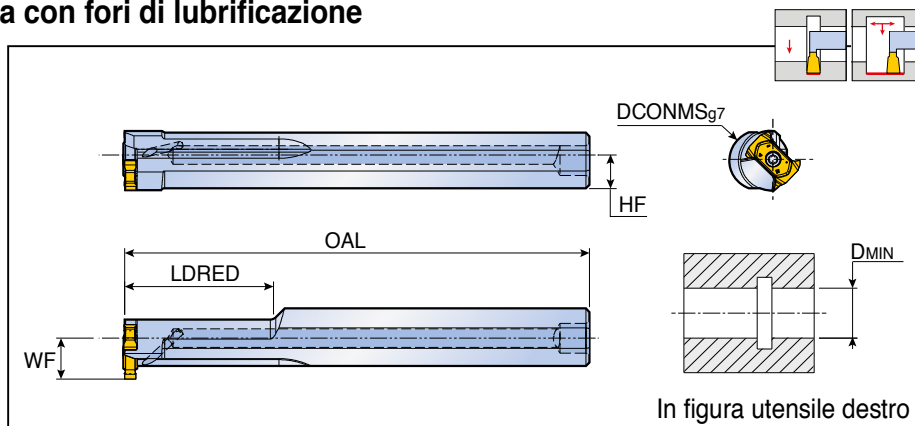

Descrizione	Dimensioni (mm)						Inserto
	DCONMS	OAL	LDRED	WF	DMIN	HF	
<b>TQHIR/L 16-16.5-14</b>	16	125	40	11	16.5	7.5	TQIS 14
<b>20-16.5-14</b>	20	125	40	13	16.5	9	

## Ricambi

Descrizione	Vite	Chiave	Tappo	
	<b>TQHIR/L 16</b>	TS 25075I/HG	T 8	PL 16
<b>TQHIR/L 20</b>	TS 25075I/HG	T 8	PL 20	

# TQIS 14



## Inserto a 4 taglianti per scanalatura interna poco profonda

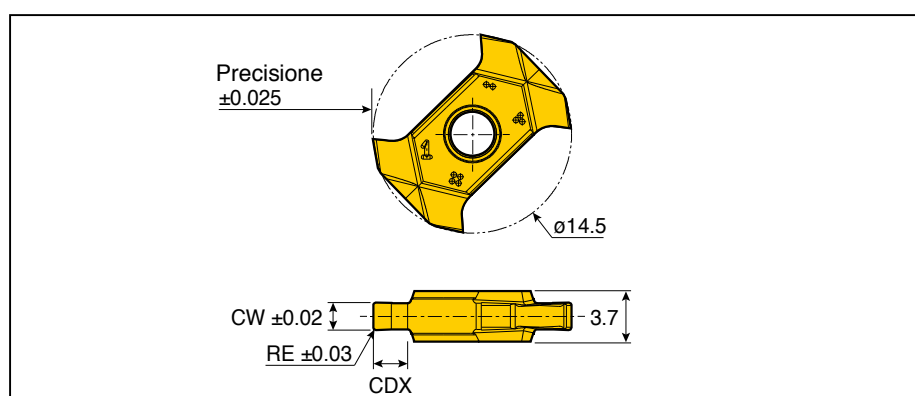

Descrizione	Avanz. (mm/giro)	Dimensioni (mm)			Grado
		CW	RE	CDX	TT9080
<b>TQIS 14-1.50-0.10</b>	0.02-0.07	1.50	0.10	2.00	●
<b>14-2.00-0.10</b>	0.03-0.08	2.00	0.10	2.50	●
<b>14-2.00-0.20</b>	0.03-0.08	2.00	0.20	2.50	●
<b>14-2.50-0.20</b>	0.03-0.09	2.50	0.20	2.50	●
<b>14-3.00-0.20</b>	0.03-0.10	3.00	0.20	2.50	●

●: Standard