



# CUTSFEED

HIGH FEED PARTING

**Nuovo Inserto ad alta rigidità  
di bloccaggio per troncatura  
e scanalatura**

✓ Alta  
produttività  
e maggiore durata

✓ Maggiore  
velocità e  
avanzamento

✓ Semplice e rigido sistema  
di bloccaggio

✓ Refrigerante ad alta pressione  
sia sopra che sotto l'inserto



# SFGB



## Lama per taglio e scanalatura profonda

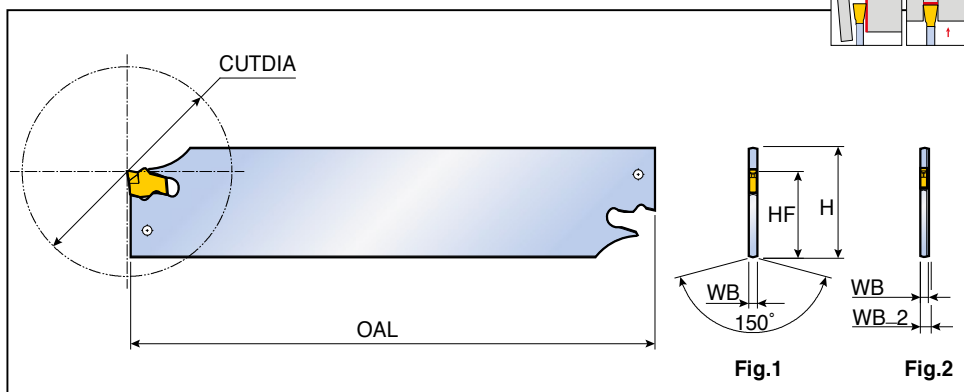

Descrizione	Misura sede inserto	Dimensioni (mm)						Fig.	Blocco	Inserto
		H	HF	OAL	WB	WB_2	CUTDIA			
<b>SFGB 32-1.6</b>	1*	32	24.8	150	1.3	2.5	38	2	TTBU	SFC
<b>32-2</b>	2	32	24.8	150	1.8	-	-			SFJ
<b>32-3</b>	3	32	24.8	150	2.5	-	100			

• \* : Solo per inserto SFC 1.6

# SFGB-TB



## Lama per taglio e scanalatura profonda con fori per refrigerante ad alta pressione

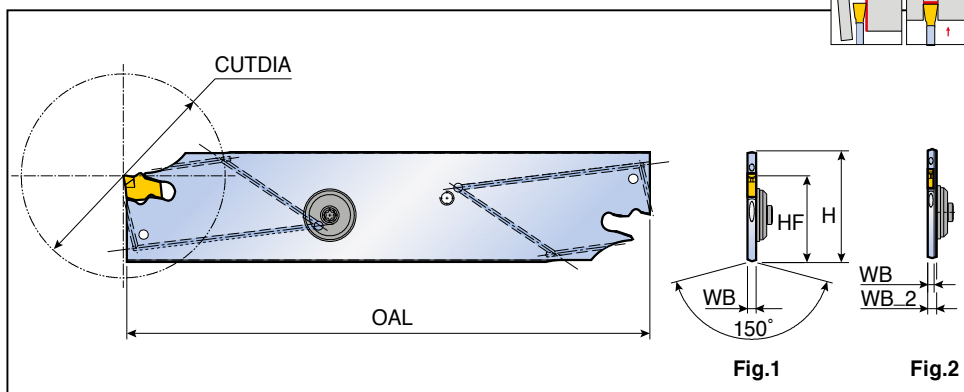

Descrizione	Misura sede inserto	Dimensioni (mm)						Fig.	Blocco	Inserto
		H	HF	OAL	WB	WB_2	CUTDIA			
<b>SFGB 32-2-TB</b>	2	32	24.8	150	1.8	2.5	50	2	TTBU..-TB	SFC
<b>32-3-TB</b>	3	32	24.8	150	2.5	-	1			SFJ

## Ricambi

Descrizione	Vite con guarnizione	Estrattore		
	<b>SFGB</b>	-	ETG 3-4	
<b>SFGB -TB</b>	SGC 340	ETG 3-4		

• L'estrattore deve essere acquistato separatamente

# SFER/L



## Utensili esterni per troncatura e scanalatura profonda

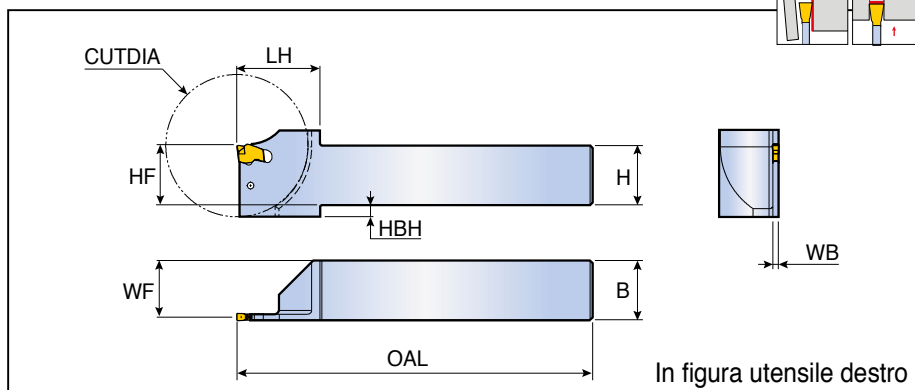

Descrizione	Misura sede inserto	Dimensioni (mm)										Inserto
		H	HF	B	OAL	LH	WF	WB	HBH	CUTDIA		
<b>SFER/L 2020-1.6T22-D45</b>	1*	20	20	20	150	29.5	19.4	1.3	2.5	45	SFC	
<b>2525-2T25-D50</b>	2	25	25	25	150	32	24.1	1.8	-	50	SFJ	
<b>2525-3T30-D60</b>	3	25	25	25	150	35	23.8	2.4	5	60	SFJ	

• \*: Solo per inserto SFC 1.6

# SFER/L-TB



## Utensili esterni per troncatura e scanalatura con fori refrigerante ad alta pressione

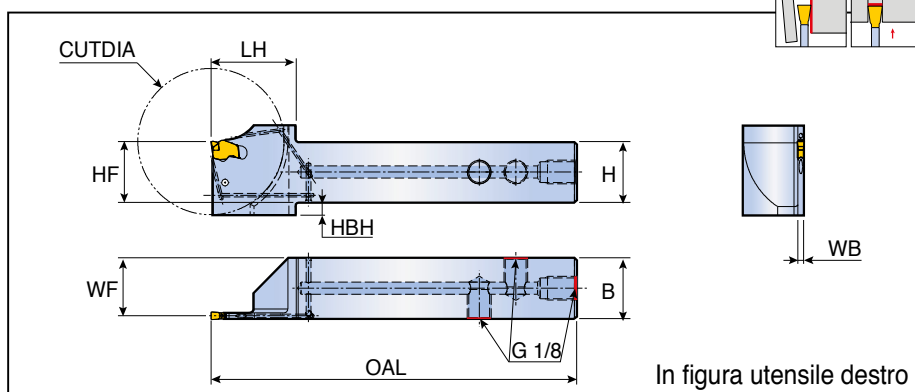

Descrizione	Misura sede inserto	Dimensioni (mm)										Inserto
		H	HF	B	OAL	LH	WF	WB	HBH	CUTDIA		
<b>SFER/L 2525-2T25-D50-TB</b>	2	25	25	25	15	32	24.1	1.8	-	50	SFC	
<b>2525-3T30-D60-TB</b>	3	25	25	25	15	35	23.8	2.4	5	60	SFJ	

## Ricambi

Descrizione	Tappo	Chiave	Estrattore	
<b>SFER/L</b>	-	-	ETG 3-4	
<b>SFER/L-TB</b>	PLG G1/8-L6.5	L-W 5	ETG 3-4	

• L'estrattore deve essere acquistato separatamente

# THTBR/L-TB



## Portalama triangolare con lubrificazione ad alta pressione

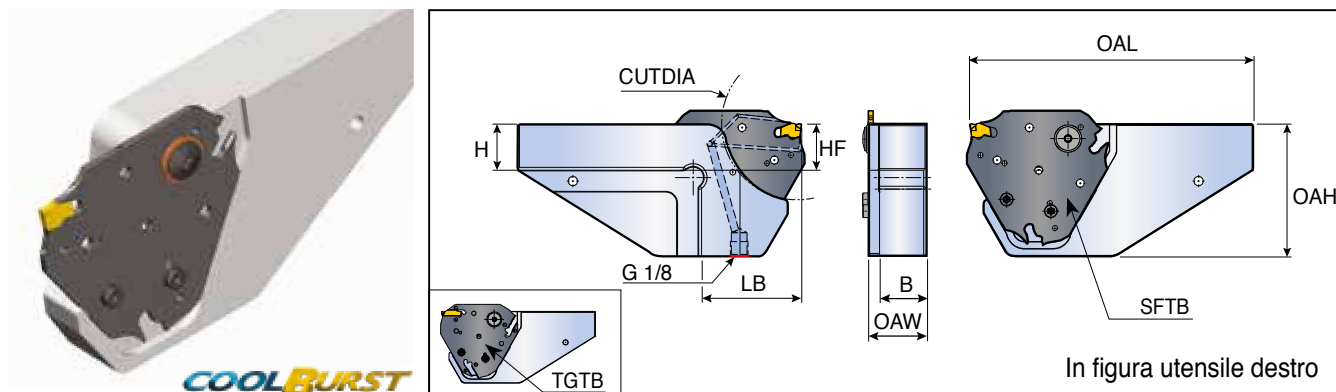

Descrizione	Dimensioni (mm)								Lama
	H	HF	B	OAL	OAH	OAW	LB	CUTDIA	
<b>THTBR/L 20-D52-TB</b>	20	20	17.5	125	52	23.5	40	52	SFTB
<b>25-D52-TB</b>	25	25	22.5	135	52	28.5	40	52	TGTB
<b>20-D82-TB</b>	20	20	17.5	140	72	23.5	51.5	82	
<b>25-D82-TB</b>	25	25	22.5	150	72	28.5	51.5	82	
<b>25-D120-TB</b>	25	25	22.5	165	95	28.5	67	120	SFTB
<b>32-D120-TB</b>	32	32	29.0	165	95	35.0	67	120	

## Ricambi

Descrizione	Vite	O-Ring	Chiave	
	<b>THTBR/L-TB</b>	SH M4X0.7X10-TX	O-RING ID10X2	T 20

# SFTB-TB



Lama triangolare per inserto CUT-SPEED con lubrificazione ad alta pressione



**COOLBURST**

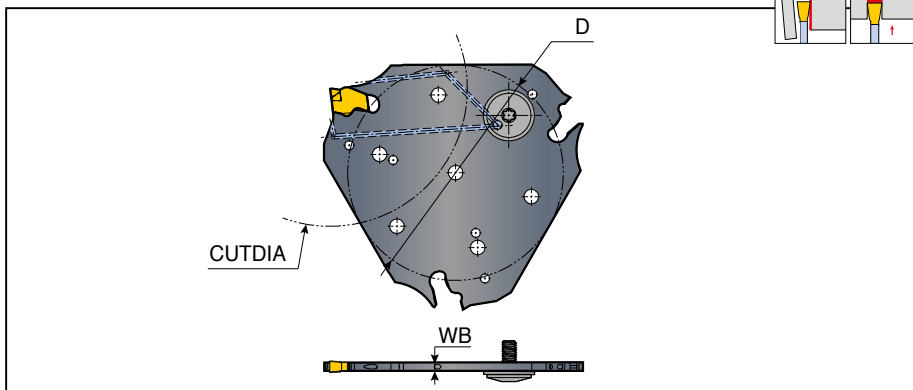

Descrizione	Misura sede inserto	Dimensioni (mm)			Inserto
		D	WB	CUTDIA	
<b>SFTB D52-2-TB</b>	2	53.18	1.8	5	SFC SFJ
<b>D52-3-TB</b>	3	53.18	2.5	52	
<b>D82-2-TB</b>	2	64.30	1.8	82	
<b>D82-3-TB</b>	3	64.30	2.5	82	
<b>D120-2-TB</b>	2	85.45	1.8	120	
<b>D120-3-TB</b>	3	85.45	2.5	120	

# TGTB-TB



Lama triangolare per inserto T-CLAMP con lubrificazione ad alta pressione



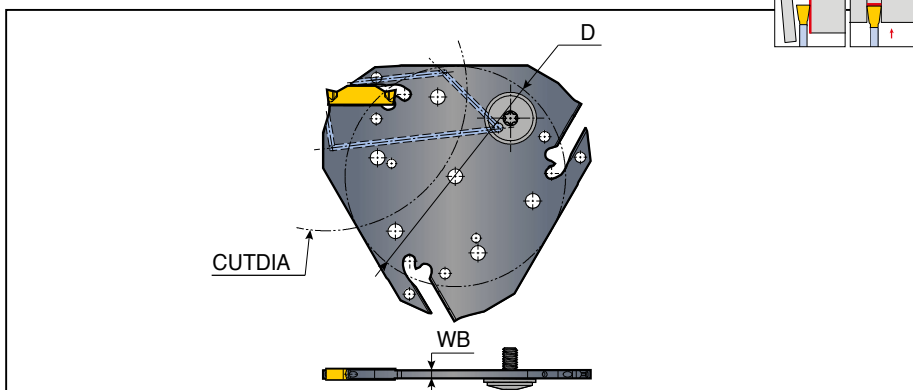

**COOLBURST**



Descrizione	Misura sede inserto	Dimensioni (mm)			Inserto
		D	WB	CUTDIA	
<b>TGTB D52-2-TB</b>	2	53.18	1.8	52	TDC / J / T TDXU / XT TSC / J
<b>D52-3-TB</b>	3	53.18	2.5	52	
<b>D82-2-TB</b>	2	64.30	1.8	82	
<b>D82-3-TB</b>	3	64.30	2.5	82	

## Ricambi

Descrizione	Vite con guarnizione	Estrattore		
				
<b>SFTB-TB</b>	SGC 340-Q	ETG 3-4	-	
<b>TGTB-TB</b>	SGC 340-Q	-	EDG 33B	

• L'estrattore deve essere acquistato separatamente

## Inserto mono tagliente per troncatura e scanalatura con romptruciolo tipo C

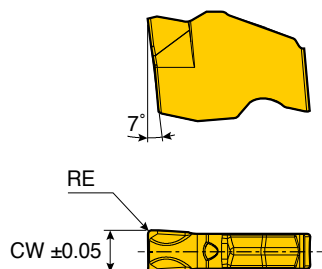

Misura	Dimensioni (mm)			
	CW	RE		
<b>1.6</b>	1.6	0.2		
<b>2</b>	2.0	0.2		
<b>3</b>	3.0	0.2		

Inserto	Descrizione	Misura sede inserto	Avanz. (mm/giro)	Cermet		Rivestito				Non rivestito		
				CT3000		TT7505	TT6080	TT5100	TT9080	TT7220	TT8020	K10
	<b>SFC 1.6</b>	1	0.05-0.15						●		●	
	<b>2</b>	2	0.08-0.2						●		●	
	<b>3</b>	3	0.10-0.2						●		●	

●: Standard

## Inserto mono tagliente per troncatura e scanalatura con romptruciolo tipo J

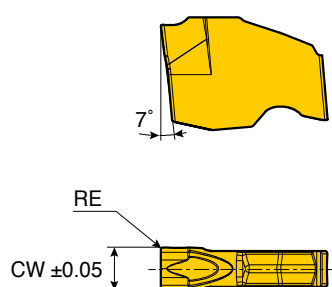

Misura	Dimensioni (mm)			
	CW	RE		
<b>2</b>	2.0	0.2		
<b>3</b>	3.0	0.2		

Inserto	Descrizione	Misura sede inserto	Avanz. (mm/rev)	Cermet		Rivestito				Non rivestito		
				CT3000		TT7505	TT6080	TT5100	TT9080	TT7220	TT8020	K10
	<b>SFJ 2</b>	2	0.05-0.15						●		●	
	<b>3</b>	3	0.08-0.20						●		●	

●: Standard