



RHINOXTURN

XNMG 70° LINE

**Inserto bilaterale rombico a 70°
dalla grande versatilità**



✓ Multifunzione per applicazioni medie e di finitura



✓ Basse forze di taglio e vibrazioni



✓ Inserto bilaterale



✓ Per lavorazione di acciaio

✓ Ottimo controllo truciolo ed evacuazione



TaeguTec
Member IMC Group

XNMG

Inserto negativo rombico a 70°

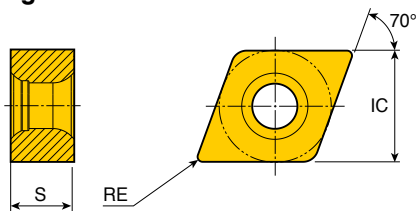

Misura	Dimensioni (mm)		
	IC	S	RE
09	8.7	4.76	0.4
11	11.11	5.56	0.4-1.2

Inserto	Descrizione	ap (mm)	Avanz. (mm/giro)	Cermet		Rivestito CVD										Rivestito PVD										
				PV3010	CT3000	TT7005	TT7015	TT8105	TT8115	TT8125	TT8135	TT9215	TT9225	TT9235	TT5100	TT7100	TT5080	TT8020	TT9020	TT9080						
	XNMG 090404 FLP	0.20-1.50	0.07-0.30							•	•	•														
	XNMG 110504 FGP	0.25-2.00	0.07-0.30							•	•	•														
	110508 FGP	0.30-2.00	0.10-0.35							•	•	•														
	110512 FGP	0.35-2.00	0.15-0.40							•	•	•														
	XNMG 110508 MLP	0.50-3.50	0.10-0.40							•	•	•														
	110512 MLP	0.60-3.50	0.15-0.50							•	•	•														

•: Standard

Utensili tipo T-Holder

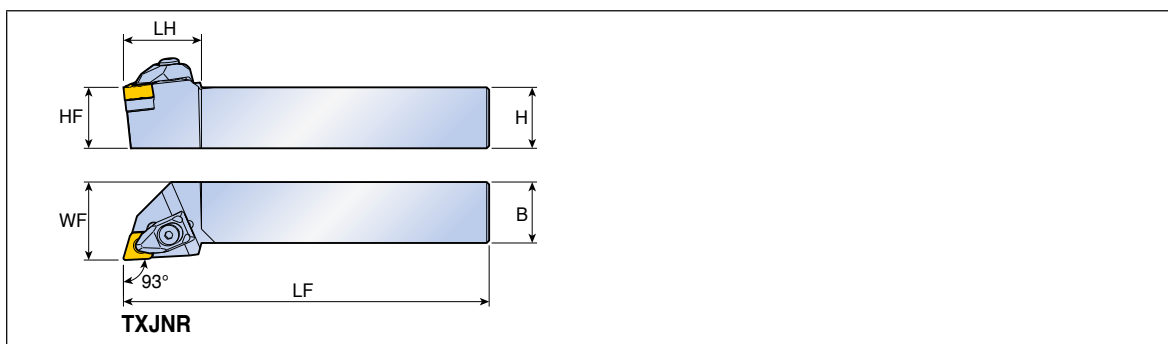

Angolo d'attacco	Descrizione	Dimensioni (mm)						Inserto
		H	HF	B	LF	LH	WF	
93° 	TXJNR/L 2020 K0904	20	20	20	125	25	25	XNMG 0904...
	2525 M0904	25	25	25	150	25	32	
	2020 K1105	20	20	20	125	32	25	XNMG 1105...
	2525 M1105	25	25	25	150	32	32	

Ricambi

Descrizione	Staffa	Vite staffa	Molla	Sottopiacchetta	Vite sottopiacchetta	Chiave	
...0904	DLM 2.5-NX	DLS 3	DSP 3	TSX 2.73	SO 40085I	L-W 2.5	T 15
...1105	DLM 3.5-NX	DLS 4	DSP 4	TSX 3.53	SO 50090I	L-W 3	T 20

TXJNR/L-TB

Utensili tipo T-Holder con lubrificazione ad alta pressione

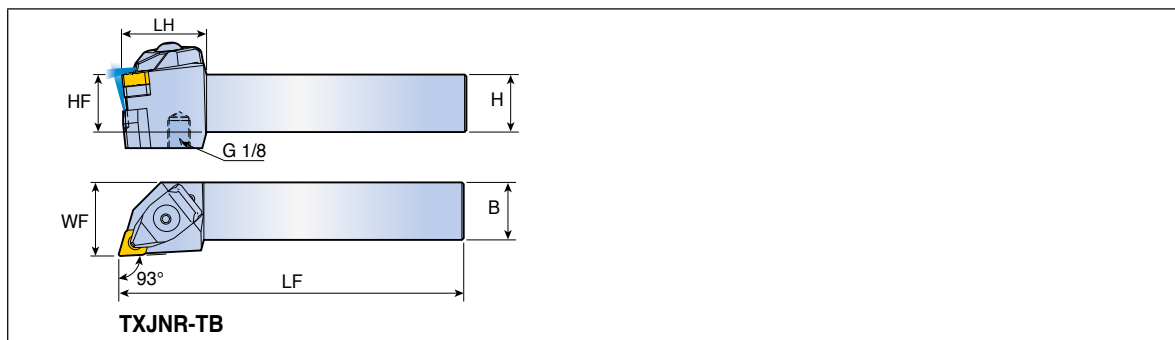

Angolo d'attacco	Descrizione	Dimensioni (mm)						Inserto
		H	HF	B	LF	LH	WF	
93°	TXJNR/L 2525 M0904-TB	25	25	25	150	30	32	XNMG 0904...
	2525 M1105-TB	25	25	25	150	37	32	XNMG 1105...

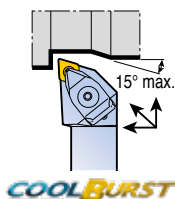

Ricambi

Descrizione	Staffa	Vite staffa	Molla	O-ring superiore	O-ring inferiore	Sottoplacc.	Vite sottoplacc.	Chiave	
...0904	DLM 3-NX-TB	BH M4x0.7x16-TB	DSP 3	O-RING ID4.47x1.78	O-RING ID6.07x1.78	TSX 2.73	SO 40085I	L-W 3	T 15
...1105	DLM 3.5-NX-TB	BH M5x0.8x21-MO-TB	DSP 4	O-RING ID5.28x1.78	O-RING ID7.59x2.62	TSX 3.53	SO 50090I	L-W 3	T 20

Utensili tipo T-Holder

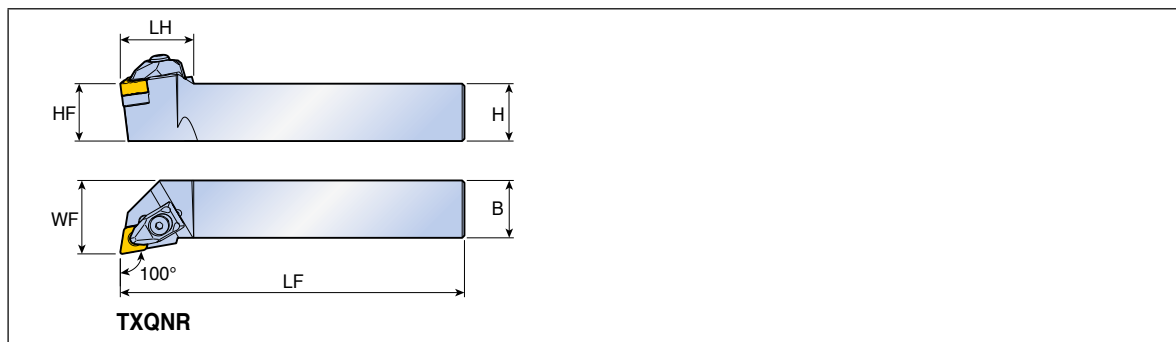

Angolo d'attacco	Descrizione	Dimensioni (mm)						Inserto
		H	HF	B	LF	LH	WF	
 100°	TXQNR/L 2020 K0904	20	20	20	125	25	25	XNMG 0904...
	2525 M0904	25	25	25	150	25	32	
	2020 K1105	20	20	20	125	30	25	XNMG 1105...
	2525 M1105	25	25	25	150	32	32	

Ricambi

Descrizione	Staffa	Vite staffa	Molla	Sottoplacchetta	Vite sottoplacchetta	Chiave	
...							
...0904	DLM 2.5-NX	DLS 3	DSP 3	TSX 2.73	SO 400851	L-W 2.5	T 15
...1105	DLM 3.5-NX	DLS 4	DSP 4	TSX 3.53	SO 500901	L-W 3	T 20

Bareni con bloccaggio a leva ad uncino

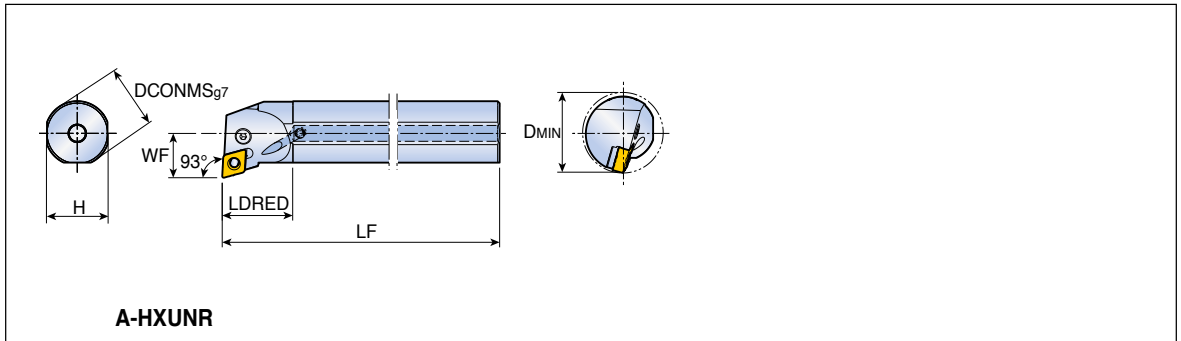

Angolo d'attacco	Descrizione	Dimensioni (mm)						Inserto
		DCONMS	H	LF	LDRED	WF	DMIN	
93°	A32S HXUNR/L 1105	32	30	250	35	22	40	XNMG 1105...

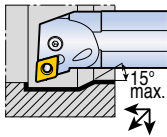

Ricambi

Descrizione	Leva	Vite leva	Sottoplacchetta	Molla Sottoplacc.	Chiave
...1105	LCL 11-NX	LCS 4S	LSX 3.52B	LSP 4	L-W 3

A-SXQNR/L A-SXUNR/L

Bareni con bloccaggio a vite

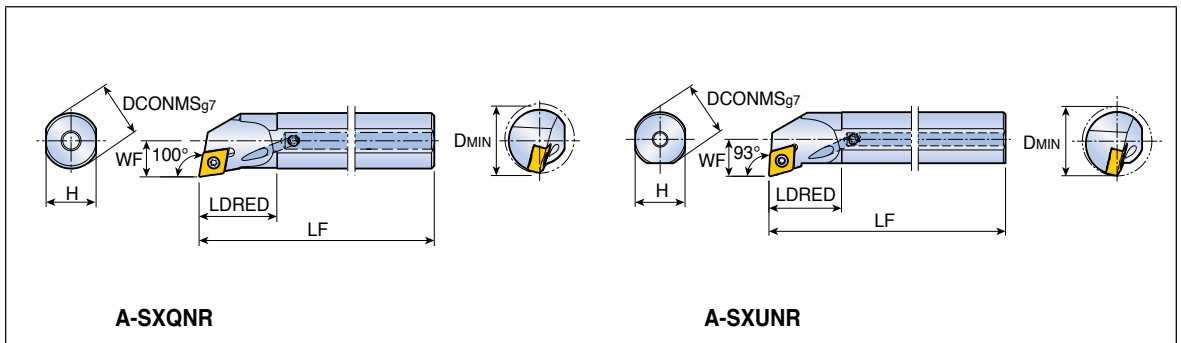

Angolo d'attacco	Descrizione	Dimensioni (mm)						Inserto
		DCONMS	H	LF	LDRED	WF	DMIN	
100°	A16Q SXQNR/L 0904	16	15	180	24.5	11	20	XNMG 0904...
	A20Q SXQNR/L 0904	20	18	180	28	13	25	
	A20Q SXQNR/L 1105	20	18	180	28	13	25	XNMG 1105...
93°	A25R SXUNR/L 1105	25	23	200	33.4	17	32	

Ricambi

Descrizione	Vite	Chiave			
	...0904	TS 30080I/HG	T 9		
...1105	TS 40G110I	T 15			

A-TXQNR/L A-TXUNR/L

Bareni con bloccaggio tipo T-Holder

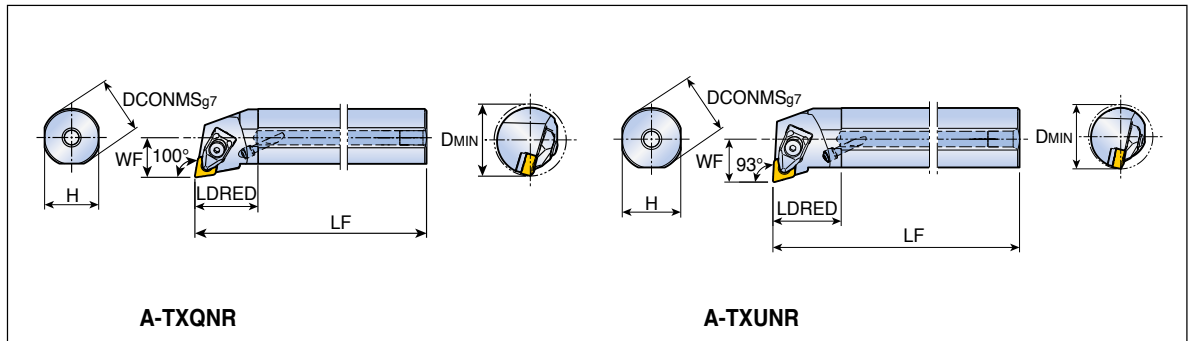

Angolo d'attacco	Descrizione	Dimensioni (mm)						Inserto
		DCONMS	H	LF	LDRED	WF	DMIN	
100°	A25R TXQNR/L 1105	25	23	200	33.4	17	32	XNMG 1105...
	A32S TXQNR/L 1105	32	30	250	35	22	40	
93°	A32S TXUNR/L 1105	32	30	250	35	22	40	

Ricambi

Descrizione	Staffa	Vite staffa	Molla	Sottopiacchetta	Vite sottopiacchetta	Ugello	Chiave	
A25R...1105	DLM 3.5-NX	DLS 4	DSP 4	-	-	NZ 62	L-W 3	-
A32S...1105	DLM 3.5-NX	DLS 4	DSP 4	LSX 3.52B	TS 50A105I	NZ 62	L-W 3	T 20